

B3S-MF Sonar Acoustic Center

*MF = Multi Frequency

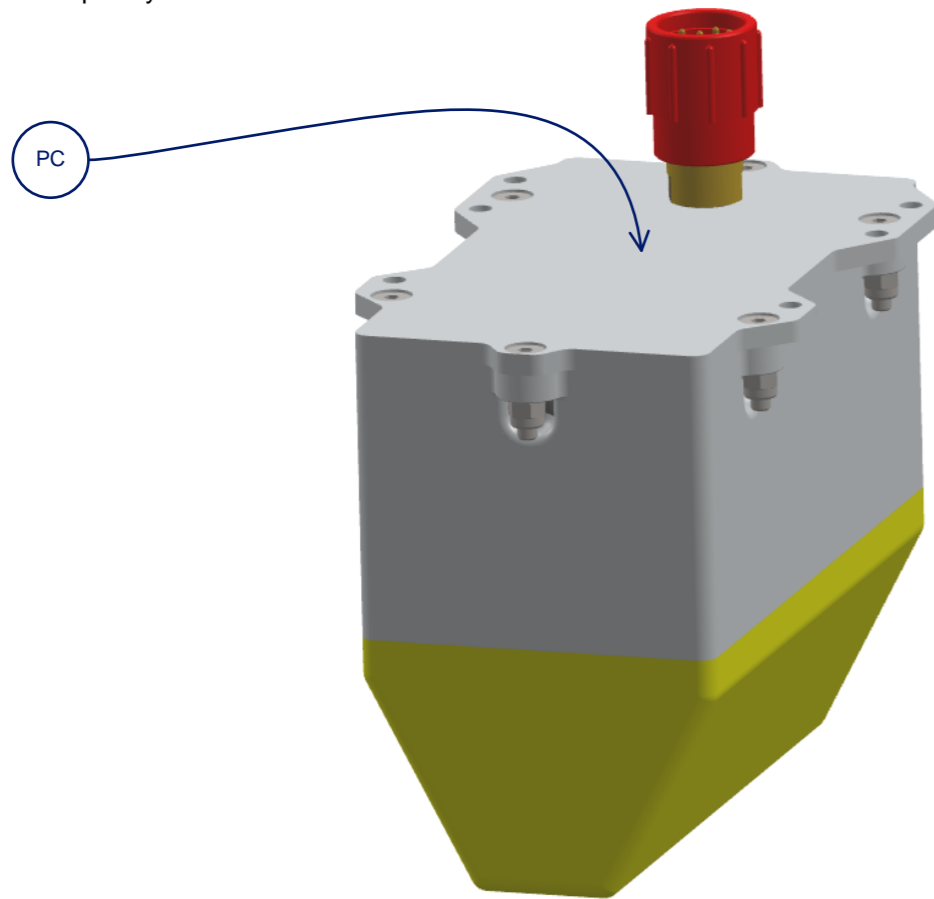

B3S Sonar

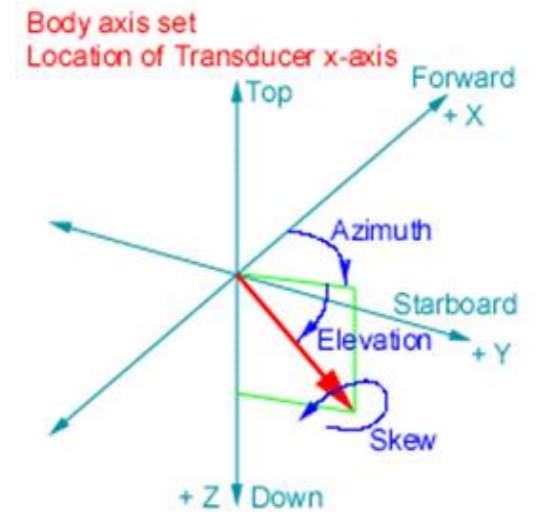

Acoustic center offset with Pole Center (PC)

Item #	Designation	Forward (X)	Starboard (Y)	Z
PC	Pole centre: Centre of mounting pole	0	0	0
TP	Port side transducer acoustic center	0	- 36.3	123,2
TS	Starboard side transducer acoustic center	0	36.3	123,2

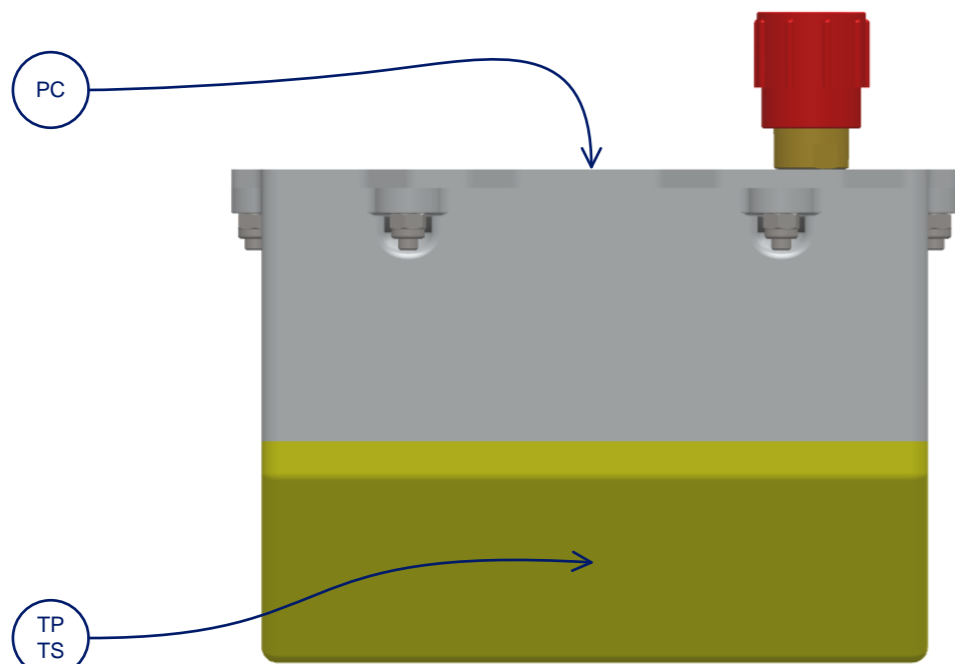

Side View (Port)

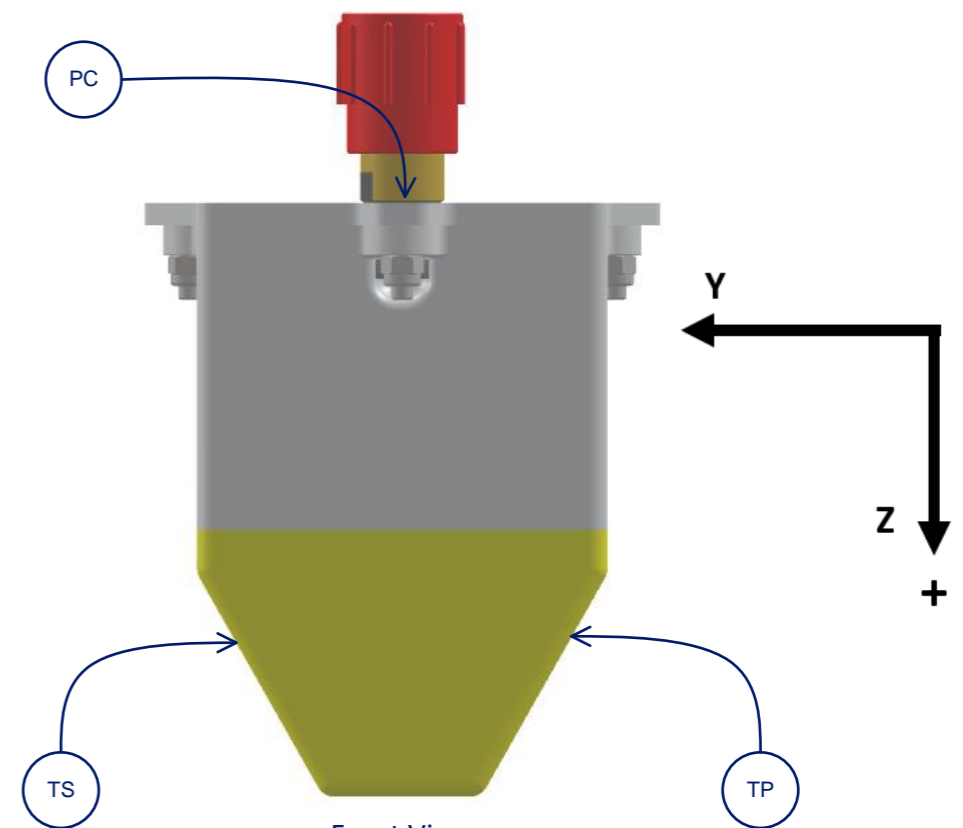

Front View

All dimensions are in mm.
Not to scale

Transducer & B3S dimensions

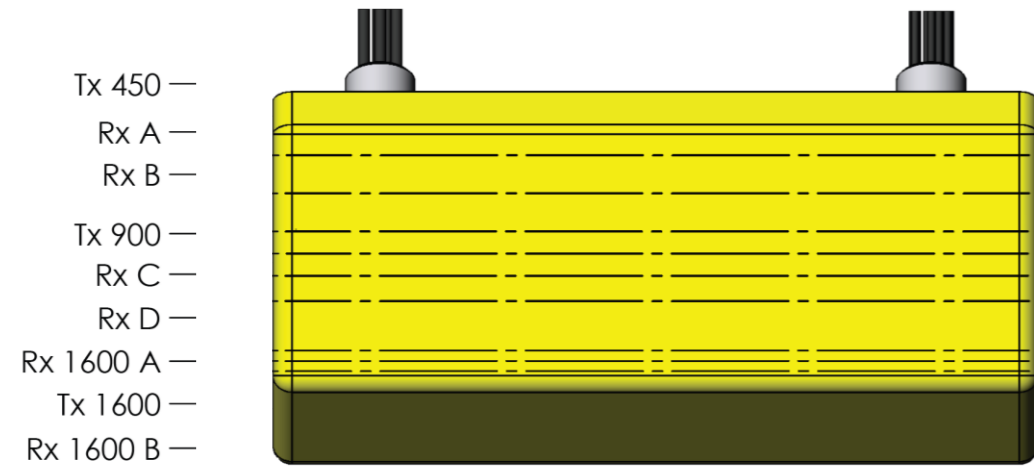

Side view

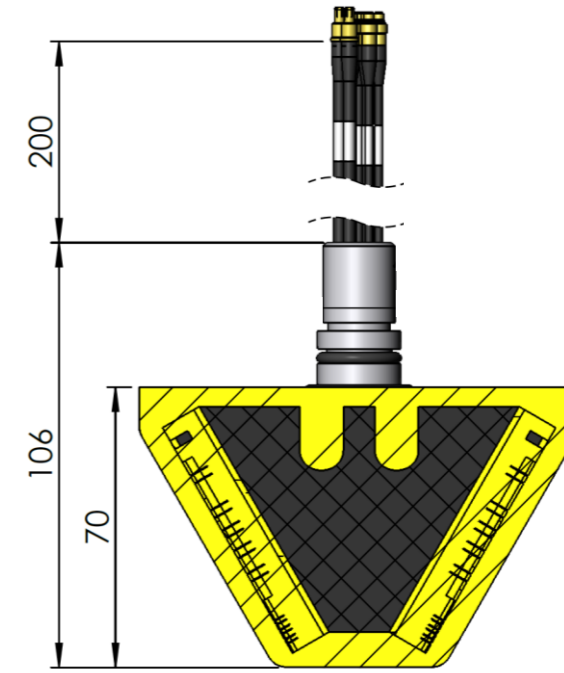

 - Acoustic centre is half-way between staves A and D for the LF and MF channels, and half-way between the 1600 A and B staves for the HF channel.

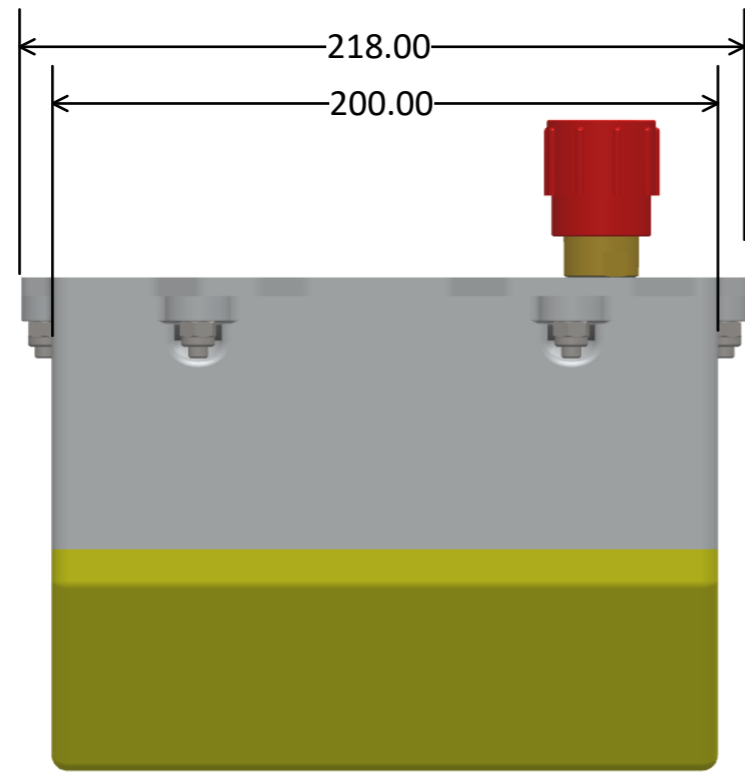

Section view

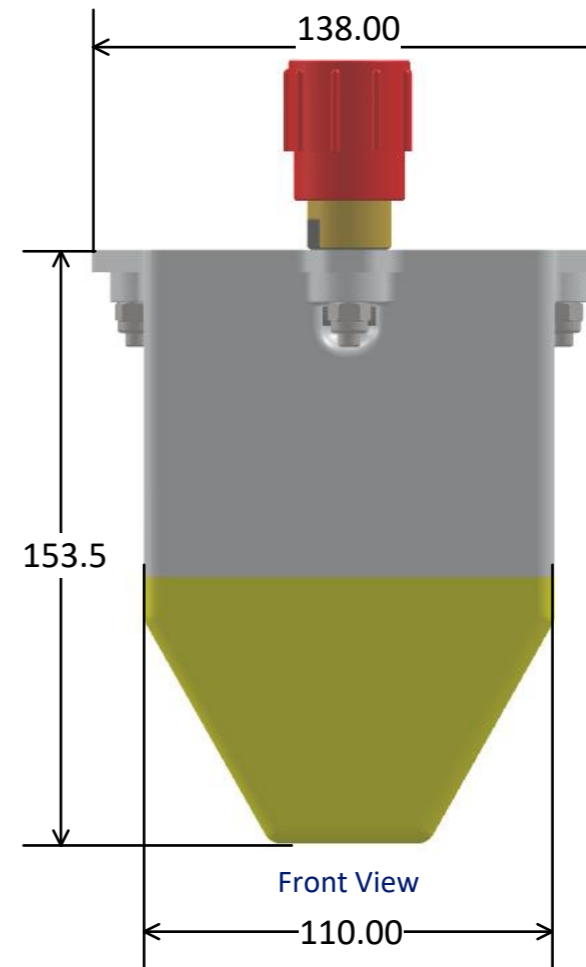

Side View (Port)



Front View

All dimensions are in mm.
Not to scale